



SAPIENZA  
UNIVERSITÀ DI ROMA

MCLab

**Model Checking Lab**

Toni Mancini, Annalisa Massini, Federico Mari,  
Igor Melatti, Ivano Salvo, **Enrico Tronci**

Computer Science Department  
Sapienza University of Rome, Italy

<http://mclab.di.uniroma1.it>

# Sapienza University of Rome

- Founded in **1303**
- The **largest** university in Europe
  - **115K** students
  - **7K** foreign students
  - **1K** incoming Erasmus students / year
- Steadily within **top 3%** world universities [Shanghai Ranking]
- **250** Bachelor & Master Programmes
- **11** Faculties
- **63** Departments



# Computer Science Dept. @ Sapienza

- **45** Faculty Members
- **23** Post-Doc Researchers
- **20** PhD Students
- Internationally active in most of the major CS **research areas**:
  - ◆ Algorithms & Data Structures
  - ◆ **Artificial Intelligence**
  - ◆ Combinatorics
  - ◆ Computational Complexity
  - ◆ **Computer Architectures**
  - ◆ Computer Networks
  - ◆ Computer Security
  - ◆ **Database Systems**
  - ◆ Web Information Retrieval
  - ◆ **Formal Methods**
  - ◆ Human-Computer Interaction
  - ◆ Computer Graphics
  - ◆ Information Theory
  - ◆ **Software Engineering**

# Model Checking Lab @ Sapienza

- Research group within the Computer Science Department
- **6** faculty members, **1** post-docs, **3** PhD students, **1** research fellow, **10** graduate students
- **Research focus:** design and development of software tools for **model-based** verification, validation and synthesis of **mission- and safety-critical embedded control systems:**
  - aerospace
  - critical infrastructures
  - transportation
  - medicine
  - smart grids



**MCLab**

# Model-Based System Verification @ MCLab

Disturbance Model (formal model of operational scenarios)

## SyLVer System Level Formal Verifier

<https://bitbucket.org/mclab/sylver-simulink-driver>

LOAD - RUN - FREE -STORE

Optimised  
Simulation  
Campaign

Simulator  
Driver

Simulator

CPS  
Model

Monitor

Omission Probability

Monitor output  
fail  
1  
0  
pass

Parallel (cluster)

Optimised  
Simulation  
Campaign

Simulator  
Driver

Simulator

CPS  
Model

Monitor

Omission Probability

Monitor output  
fail  
1  
0  
pass

Simulation Based Verification

# Model-Based Control SW Synthesis @ MCLab

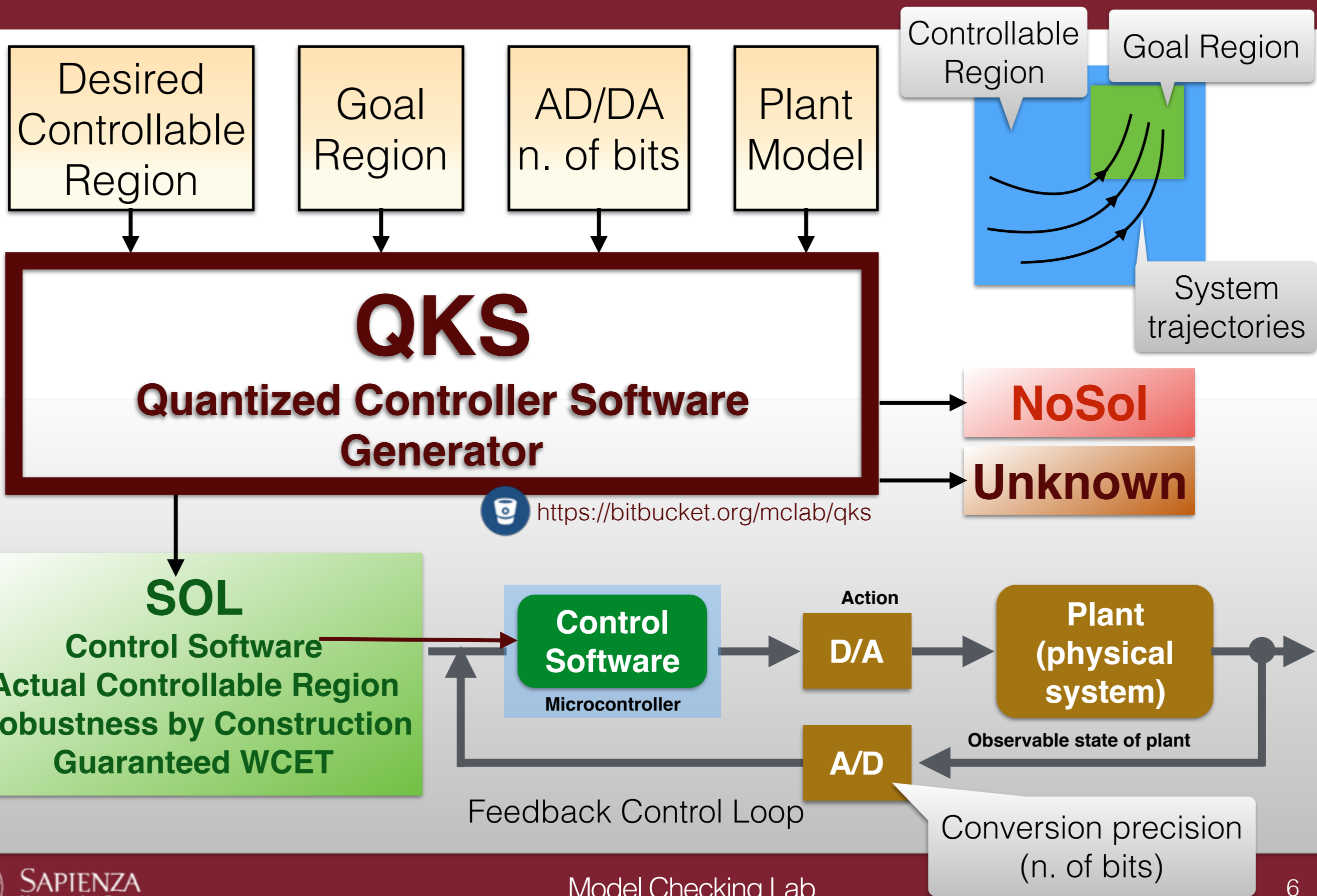

# MCLab in Aerospace

## EC FP7 Ulisse (4.8 M€)

Verification & Validation of mission planning and on-board procedures



## ESA ITI Verifying Satellite Operational Procedures (150 k€)

Verification & Validation of ground segment satellite operational procedures



## ESA ITT System & Software Functional Requirements Technique (200 k€)

Verification & Validation of system level design for satellite and avionics vehicles



# MCLab in Transportation

## MIUR Tramp, Setram, Interception (3.5 M€)

Optimal management of intermodal transportation of dangerous goods, guaranteeing security standards

Safety verification of communication protocols and control policies for the control center



## FILAS Sintesi (100 k€)

Sense and response system for critical resource management





# MCLab in Critical Infrastructures

**SAPP, IRRIS, Safeguard, SafeTunnel, Icaro (10 M€)**

Design and safety verification of control and communication systems for critical infrastructures



# MCLab in Smart Grids

## EC FP7 SmartHG (3.5 M€)

Energy Demand Aware Open Services for Smart Grid Intelligent Automation



**Coordinator:** MCLab



SAPIENZA  
UNIVERSITÀ DI ROMA

Design and formal verification of hierarchical **control policies** for the Smart Grid

SmartHG benefits: optimisation of grid **management**, minimisation of energy **cost** and CO2 **emissions**

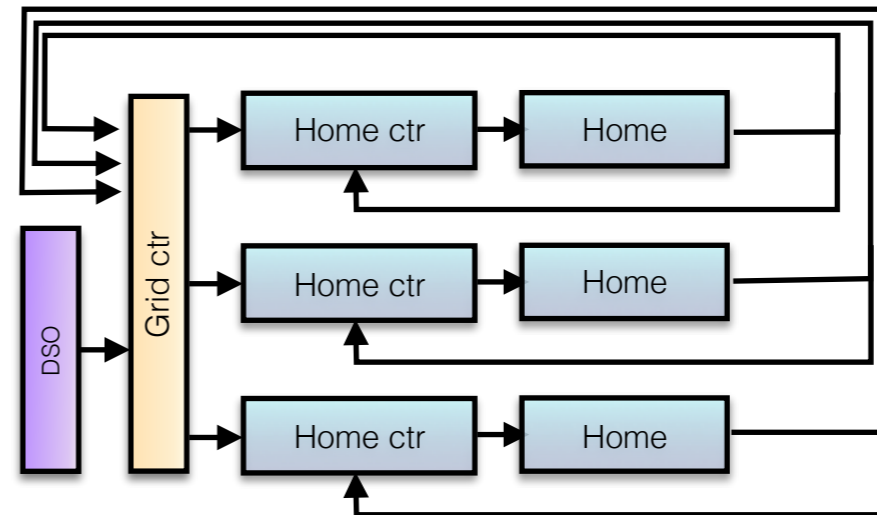

A.V. LUTKOV HEAT AND MASS TRANSFER INSTITUTE OF  
THE NATIONAL ACADEMY OF SCIENCES OF BELARUS



SAPIENZA  
UNIVERSITÀ DI ROMA

# MCLab in Medicine

## EC FP7 Paeon (2.5 M€)

Model Driven Computation of Treatments for Infertility Related Endocrinological Diseases



**Coordinator:** MCLab



**SAPIENZA**  
UNIVERSITÀ DI ROMA

Modelling of **human physiology** (virtual physiological human)

Model based automatic verification and synthesis of **personalised** clinical treatments

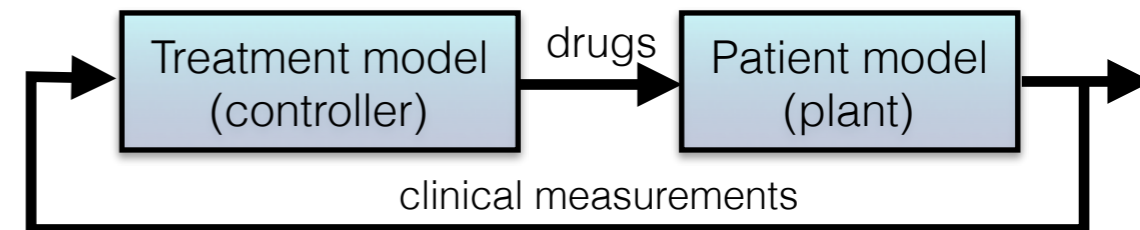

# Contacts

Toni Mancini, Annalisa Massini, Federico Mari,  
Igor Melatti, Ivano Salvo, **Enrico Tronci**

Computer Science Department  
Sapienza University of Rome  
Via Salaria 113  
00198 Rome, Italy

[tronci@di.uniroma1.it](mailto:tronci@di.uniroma1.it)

<http://mclab.di.uniroma1.it>

